

Plastic Greenhouse Manual

Planning, Construction, and Operation

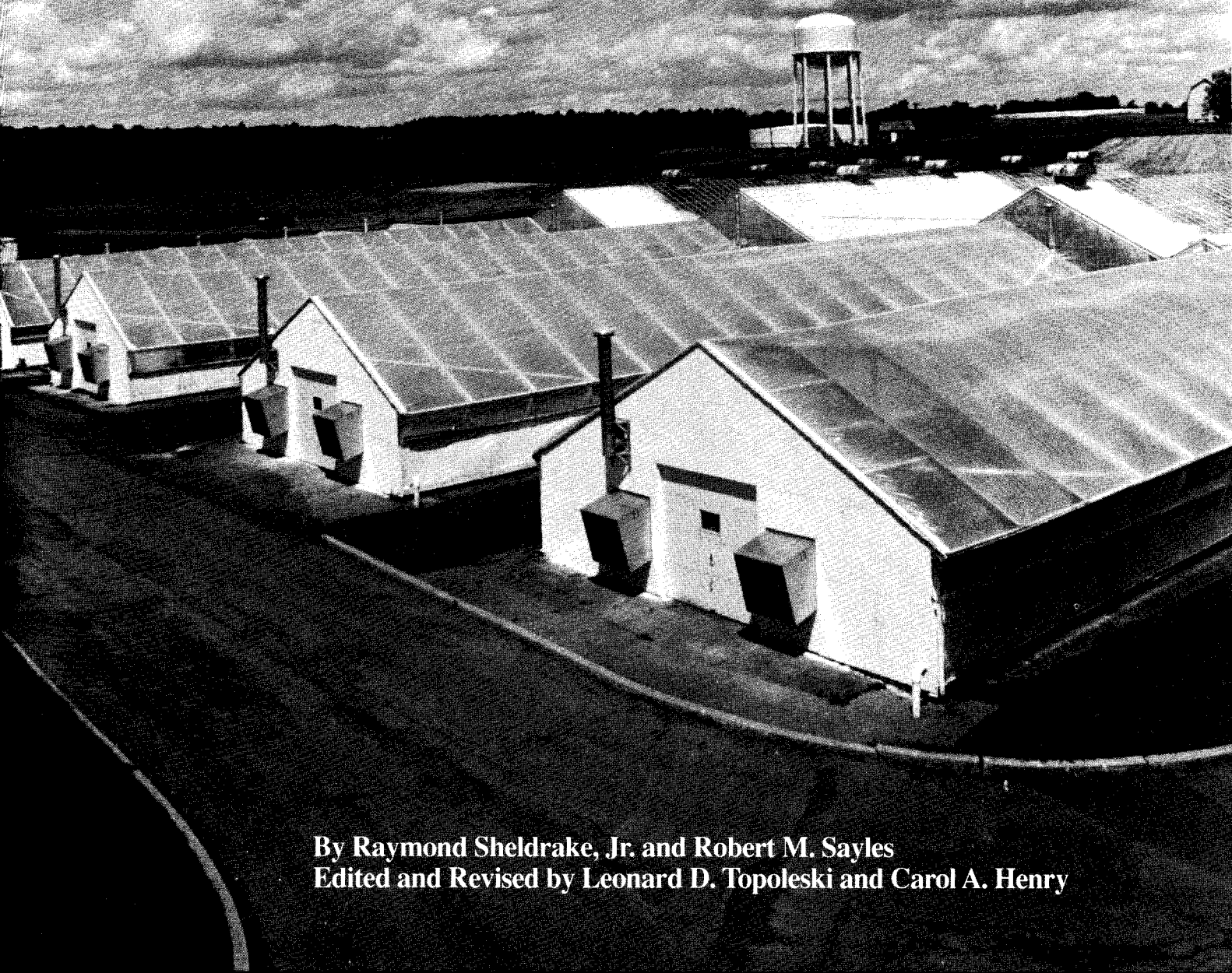

By Raymond Sheldrake, Jr. and Robert M. Sayles
Edited and Revised by Leonard D. Topoleski and Carol A. Henry

Plastic Greenhouse Manual Planning, Construction, and Operation

**By Raymond Sheldrake, Jr. and Robert M. Sayles
Edited and Revised by Leonard D. Topoleski and Carol A. Henry
Revised 1992**

Department of Fruit and Vegetable Science
College of Agriculture and Life Sciences
Cornell University, Ithaca, NY 14853

Fruit and Vegetable Science Report #22

**Special appreciation to Sue Thompson
for her enthusiasm and assistance in typing
the original draft for this manual**

This manual was designed to offer the new, as well as the experienced greenhouse operator a fairly complete and up to date treatise on the subject. Before any construction starts, it is suggested that you read the manual completely.

The proceeds from the sale of this manual will be used to update future copies and help finance further research in this important field. We hope you find it useful.

PLASTIC GREENHOUSE MANUAL

TABLE OF CONTENTS

Construction and Use	1
Selecting and Preparing A Site	1
Size of Greenhouse	2
Seasonal Use	2
One Layer of Plastic Versus Two	3
Types of Plastic	4
The Cornell Exterior Plywood Gusset Design	6
STEP 1. Width Considerations	6
STEP 2. Site Preparation	7
STEP 3. Posts	8
STEP 4. Cut Rafters	9
STEP 5. Side Gussets	10
STEP 6. Top Gussets	10
STEP 7. "A" Braces	10
STEP 8. Trusses	12
STEP 9. Painting	12
STEP 10. Assembling Frame	13
STEP 11. Additional Support and Stability.	13
STEP 12. Side Walls	15
STEP 13. Applying the Plastic	15
STEP 14. Install Blower	18
STEP 15. Side Wall Inflation	19
Cooling	19
Heating	20
Ventilation	23
Bill of Materials	26
Summary	27

CORNELL PLASTIC GREENHOUSES

CONSTRUCTION AND USE

Plastic covered greenhouses have proven very useful for growing early spring plants, and for producing vegetable or flower crops throughout the year.

Plastic houses may be considered temporary structures and cost considerably less than glass greenhouses, and their tax assessment is generally lower. However, initial cost and tax rate are not the most important considerations when choosing between plastic and glass. This decision should not be made without considering your long range plans.

SELECTING AND PREPARING A SITE

A plastic greenhouse is only as good as the planning and workmanship that go into it. To be of greatest value, the house must be on a site that takes advantage of windbreaks but is not shaded by trees or neighboring structures, that has good water drainage and run-off, and permits easy access during winter for fuel deliveries and general work.

Tile drains, if necessary, and water and gas lines should be installed, and the site leveled before construction begins. A good water supply must be available for efficient operation. It is also desirable to install underground electrical service before construction takes place. If a plastic greenhouse is to supplement glass houses and cold frames, it should be adapted into the overall plan for a more efficient greenhouse operation.

If peppers, eggplants, tomatoes, lettuce, chrysanthemums, or snapdragons are to be grown in ground beds, steam sterilization will be necessary. It is therefore advisable to install the permanent steam tile before construction.

Before the first greenhouse is built, locations for additional houses should be considered. The houses should be spaced 12 to 15 feet apart to accommodate sliding snow and to allow for snow removal between houses, if necessary. If retail selling is planned, then ample parking space must be provided.

SIZE OF GREENHOUSE

Most growers soon realize that their current greenhouse space is generally inadequate; therefore, it is advisable to build a unit larger than is presently required. Planning ahead now will save time and money later.

In addition to being more efficient, large greenhouse units are more economical than small units since they can be built for less money per square foot. The greenhouse size should be designed to fit the size of the two most expensive pieces of equipment -- the furnace(s) and the ventilation fan(s). The heating plant usually costs more than the structure; and for this reason there should be as much usable space as possible for the dollars spent.

The crops to be grown, and whether they are grown on benches or in ground beds, will determine the side-wall height. Side walls can be as low as 2 to 3 feet for bedding plants, but may need to be 6 feet or higher for tomatoes.

SEASONAL USE

Although many growers build plastic greenhouses with the intention of operating them for only a month or two in the spring, they often find uses for them in fall and winter. A wide variety of plants have been successfully grown in plastic-covered houses. Winter months can be difficult for greenhouse management, but well-constructed plastic houses employing two layers of plastic have performed well during extremely cold and windy weather. Many bedding plant growers grow fall crops of chrysanthemums, poinsettias, or tomatoes. The bedding plant growing season usually begins in February, and plastic greenhouses can be very useful for four or five months in this business. If the houses have properly sized fans, or if the side walls can be opened in the summer, they can be used throughout the summer as well.

If the houses are to be used during the winter and are subject to high winds, special precautions must be exercised to winterize the water lines and handle the snow. Snow usually does not stick to plastic and will slide off if space is provided to receive it.

If the plastic houses are not used in the winter, a wet snow will sometimes freeze on the plastic and cause considerable damage. Therefore, the heating system should be available as a little heat from inside will cause the snow to slide off. For wind protection, an eight-foot fence can be constructed with wire and film plastic, or with rigid fiberglass.

ONE LAYER OF PLASTIC VERSUS TWO

Plans for houses designed for one-layer covering are available from other states and from some commercial companies. New York growers, however, should NOT consider building and operating single-layer plastic covered houses. Two-layer coverings give the following advantages:

1. Two layers of plastic, properly installed, saves fuel and makes it possible to use a furnace with at least 40% less output capacity than needed in a house with a single layer of plastic. The savings on fuel more than pays for the cost of the double layer of plastic.
2. A two-layer covering reduces moisture condensation and the drip problem that is so common in houses covered with only a single layer.
3. Two layers give added insurance against torn plastic. However, with modern copolymers of plastic, torn plastic is rarely a problem.
4. Two layers of polyethylene enable one to use the newer concepts of air separation which greatly speeds covering.

The air space between the two layers of plastic offers an excellent degree of insulation. Ideally, the air space should be uniform and less than one inch. However, a one inch air space is not possible since the film layers would then touch in places and the effect would be lost. The best approach is to apply both layers of 6 mil polyethylene and then apply constant air pressure (0.20 and 0.30 inches of water column). At points of attachment to the house the films will touch and in the middle areas the film may be 10-12 inches apart. It is not a perfect situation, but the advantages are much greater than single layer or any other method of using double layers. (See **Air Supply...**, Page 22).

An inner layer of plastic has proven beneficial in glass houses; but the plastic is difficult to apply because of the superstructure of the house. This is also true with many existing single-layer plastic houses. When both layers are applied from the outside, a tighter installation can be attained with greater ease.

A house designed for easy covering has obvious advantages.

TYPES OF PLASTIC

Most plastic greenhouses are covered with sheet-film plastic. The most popular is polyethylene, which is recommended in a 4- or 6-mil thickness (1 mil = 0.001 inch). Polyethylene is available in seamless widths up to 48 feet. However, widths greater than 16 feet are shipped folded, and construction grade polyethylene is sometimes weak along the lines where it has been folded. Therefore, if possible, use only material which is specified for greenhouse covering. The newer copolymer types will last at least two years after application. The width of plastic should be chosen before building to allow for ease of application, and as little waste as possible.

The sun's ultraviolet light speeds deterioration, consequently regular construction grade polyethylene must be replaced every year. Houses covered in late September or October will last through winter and spring, but will begin to deteriorate in July. If applied in February to April, the film will last only until mid-August.

New copolymers with ultraviolet resistance will last three years. New York State growers are encouraged to use the copolymer ultraviolet resistance plastic.

Most polyethylene films transmit about 83% of the visible light of the sun. However, a grower is more concerned with the amount of light reaching the crop. Table 1 below shows actual light transmission recorded in foot candles at bench level. The amount of the various wavelengths of light reaching the crop on March 27, 1973, is shown in Figure 1 on Page 5.

TABLE 1: LIGHT TRANSMISSION COMPARISON (IN FOOT CANDLES).

	<u>OUTDOOR</u>	<u>NEW GLASS HOUSE</u>	<u>PLASTIC (2 LAYER 6 MIL)</u>
Feb. 10 ^a	3900	3250	2650
Feb. 15 ^b	1100	910	950
Feb. 27 ^c	5300	5000	4700
Mar. 8 ^d	6000	5400	5200
Mar. 27 ^e	7600	7000	6100

^aClear day (11:00 a.m.) very cold, plastic house unheated, frost on plastic.

^bDark, cloudy winter day, snow covered ground.

^cClear day (12:00 noon).

^dClear day (11:30 a.m.).

^eClear day (11:30 a.m.).

FIGURE 1.

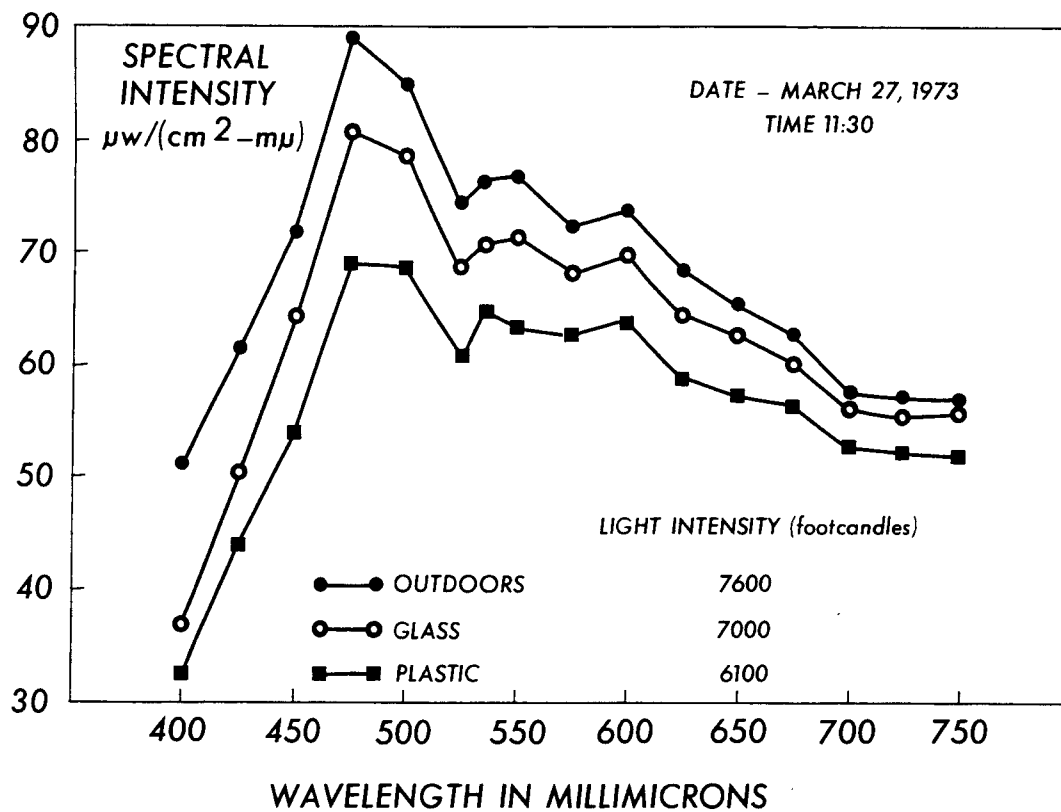

THE CORNELL EXTERIOR PLYWOOD GUSSET DESIGN

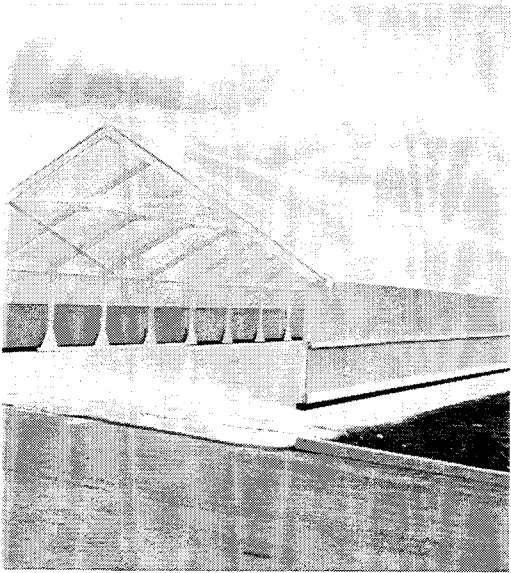

The basic structural design for the original "Twenty-One" employs an external plywood gusset. The 21 x 96 foot unit was designed as an economical structure incorporating all the modern technical knowledge for efficient greenhouse operation and plant production. The design has unique features; there are simple prefabricated trusses strengthened with external plywood trusses, two layers of plastic can be applied from the outside; and a catwalk at the ridge is provided to facilitate covering. Gusset houses are simple to build, and can be constructed by relatively unskilled laborers using standard stock lumber.

STEP 1. WIDTH CONSIDERATIONS

Decide upon the width of the house to be built. From Table 2 (next page) choose one of the three widths given. Polyethylene can be obtained in widths **ONLY** up to 48 feet. These houses use a 40 X 100 or 48 X 100 foot sheet. The house should be constructed 96 feet long to allow plenty of film for attachment. **House A** would enable attachment of the plastic at the base if the side walls are not greater than 5 feet. **House B** assumes that a portion of the side wall will be solid and the film will be attached about 3 feet down from the eaves. In **House C** the plastic is attached to the eaves and the side walls are covered separately.

NOTE: WHEN THIS BULLETIN WAS WRITTEN, 40 FEET WAS THE WIDEST WIDTH AVAILABLE, BUT NOW 48 FOOT MATERIAL IS AVAILABLE.

TABLE 2. WIDTH OF HOUSE

HOUSE	RAFTER LENGTH	INSIDE WIDTH
A	14'	22', 10"
B	16'	26', 3"
C	18'	29', 9"

STEP 2. SITE PREPARATION

The land should be leveled and any drainage tiles, electric or water lines installed **before beginning** the actual construction. The future floor of the greenhouse should be covered with gravel, or blacktopped.

Gravel Floors:

Post holes should be dug and the posts set prior to spreading the gravel. The posts should be 4 X 4 inch lumber that has been painted with, or dipped in Cuprinol, pressure treated, or some other safe preservative. The post holes should be at least 30 inches deep.

Blacktop Floors:

It is preferable to put down a good gravel base, with about 3-4 inches of blacktop. The blacktop pad should be at least 6 feet wider and longer than the house. After blacktop has been rolled thoroughly (usually by a contractor), apply dry Portland cement to the surface and sweep the floor with a pushbroom. A uniform application of water with a boom sprayer or even from rain will set the cement. This gives a well-sealed, light-colored surface that is easy to work on.

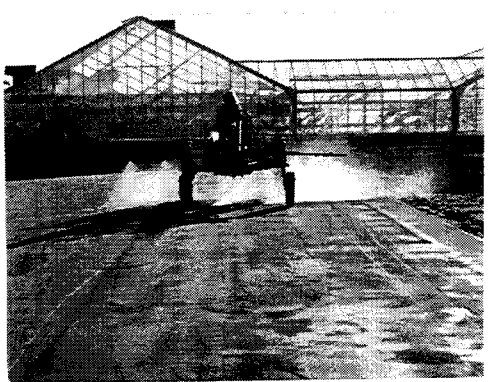
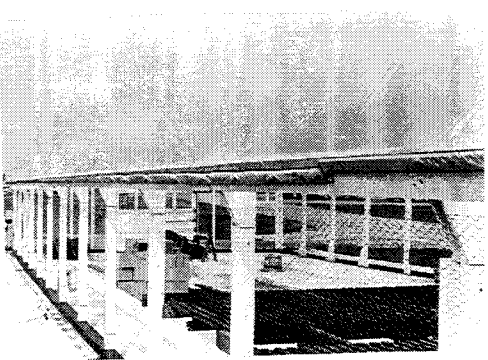
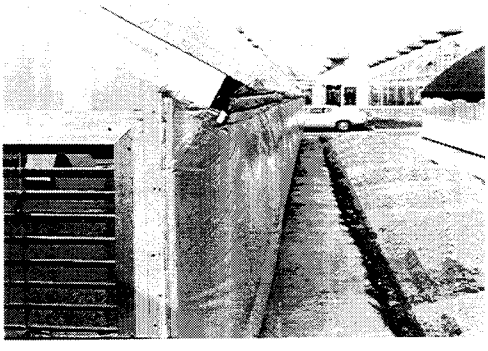
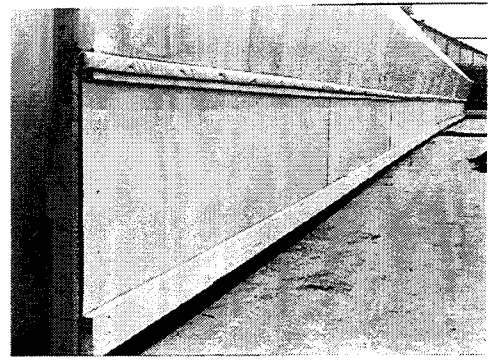

NOTE: NEVER TREAT ANY GREENHOUSE LUMBER WITH PENTACHLOROPHENOL.

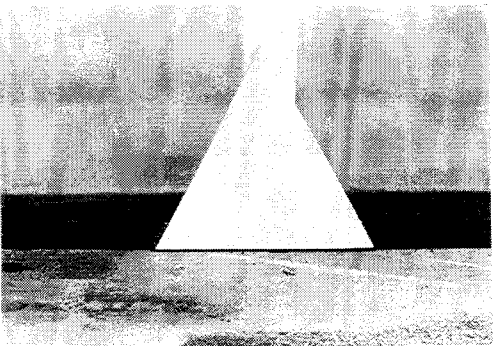
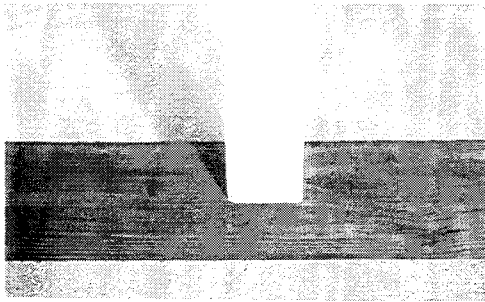
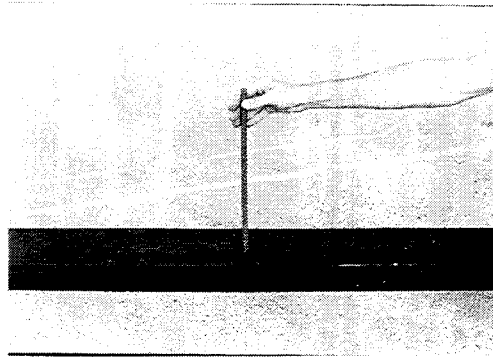

STEP 3. POSTS

With a gravel or dirt floor, drill 12 inch holes 30 inches deep, for the 4 X 4 inch posts. The inside of the posts should fit the width given in Table 2, and therefore the center of the holes will be about 4 inches wider than this dimension (two inches on each side). Plan on 6 foot rafter spacing (center to center). This means that the two end holes will need to be set about 4 inches closer, since the outside trusses are nailed to the outside of these posts. With this arrangement, standard 12 and 18 foot lumber can be used to tie the house together lengthwise. The house will be 96 feet, outside to outside.

- A. The treated posts should be set in a straight line and set plumb. Tamp gravel or a dry mix of 1 part cement to 6 parts sand or gravel around the posts. If the dry mix is used, wet down the area around the posts when they are all set. The tops will be cut off later. The length of the posts will be a function of the side wall height. They should extend 4-6 feet from the ground.
- B. If a blacktop floor is used, use 4 X 6 inch 16 foot treated lumber, laid flat, as the footer or base for the house. These should be set the exact distance apart to achieve the width chosen in Table 2. These footers should be drilled with $1/2$ - $5/8$ inch holes every 5 feet, and a steel rod, $1/2$ inch in diameter and at least 18 inches long, should be driven in with

a sledge hammer down through the blacktop and into the gravel below.

- C. The 4 X 4 posts are then set flat on the footers using the same spacing information given above. The posts are secured to the footers using triangles of 1/2 inch exterior plywood nailed to the inside. These triangles are 2 feet wide and 2 feet high.
- D. Establish the height of the post desired and with a tight line and line level, mark the posts at this height. Cut off all posts to this level. The base of the gusset on the truss will sit on this point giving an easy way to get the whole house level.

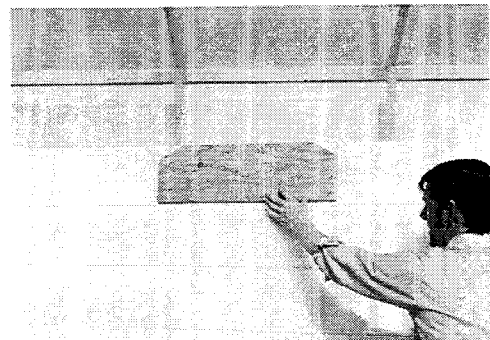
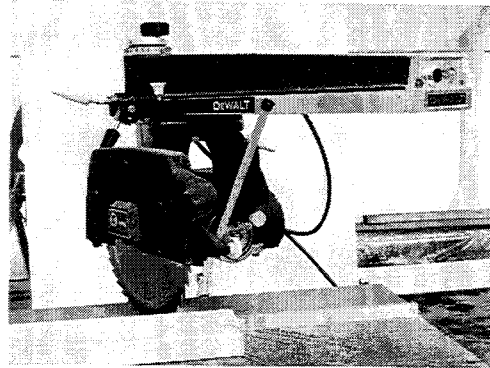

STEP 4. CUT RAFTERS

Make certain that all 2 X 6 rafter lumber is the exact length. (They can vary.) Using a radial arm saw set at 30°, cut two rafters and check the overall length again. Cut two 2 x 4 or 2 X 6 legs using the same angle. The legs need only be 5 feet in length since this will allow ample room to nail to the 4 X 4 posts. On a flat area, lay out two cut rafters and two legs and form the truss. Check the inside width and check that the angle cuts are right.

If the fit is good, these can serve as the patterns, and the remaining rafters and legs can be cut. To give a 5-6 inch flat surface for the catwalk, cut the points off the rafters at the peak (a 2 X 6 inch catwalk is used).

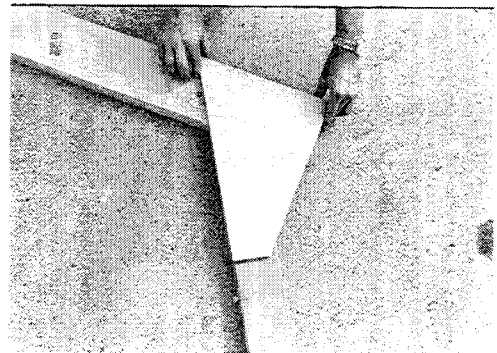
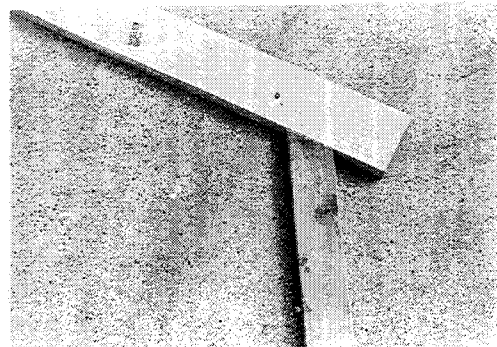

NOTE: CHECK TO MAKE SURE THAT THE GAUGE ON THE RADIAL ARM SAW IS CORRECT. A SLIGHT ADJUSTMENT MAY BE NEEDED.

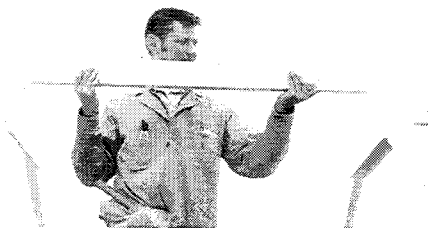
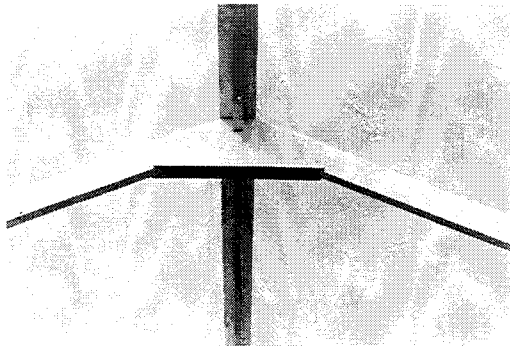
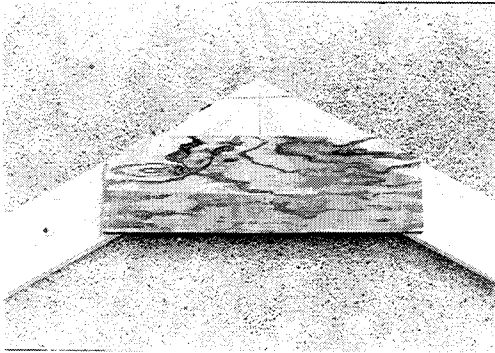

STEP 5. SIDE GUSSETS

From a 4 X 8 foot sheet of 1/2 inch exterior plywood, cut 32 side gussets using dimensions given in Figure 2 (see next page). Sixty-four (64) gussets are needed since 4 gussets are used on each truss (except the end two) and 17 trusses are needed per house. From the bottom point of each gusset, cut off about 2 1/2 inches of the point exactly the same on each gusset. This flat cut will then set flat on the top of each post. (See Figure 2, Page 11.)

STEP 6. TOP GUSSETS

The top gussets are also cut from 1/2 inch exterior plywood. They are 8 inches wide and a total length of 24 inches. Cut the plywood into 8 inch strips and proceed to mark and cut out the gussets. Thirty-four (34) top gussets are needed. The top corners are cut off to the slope of the rafters. About 2 inches were also cut off the width at the same 30° cut.

STEP 7. "A" BRACES

The cross brace that ties the two rafters together should be low enough to give the rigidity needed and also low enough to allow room for a heating/ventilation tube above it. On **House A** (see Table 2) this brace was a standard 12 foot 2 X 4; on **House B**, a one 14 foot 2 X 4; and on **House C** use a 16 foot 2 X 4.

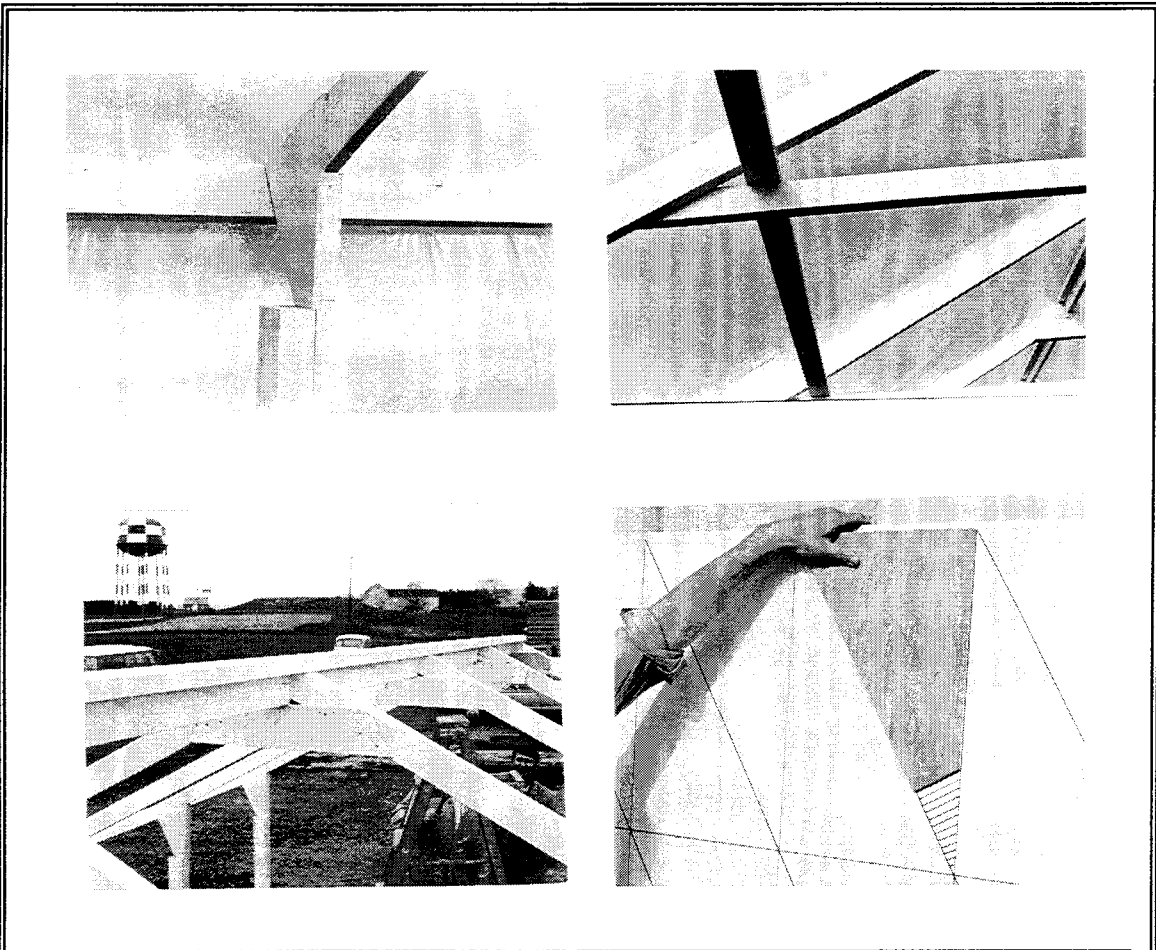
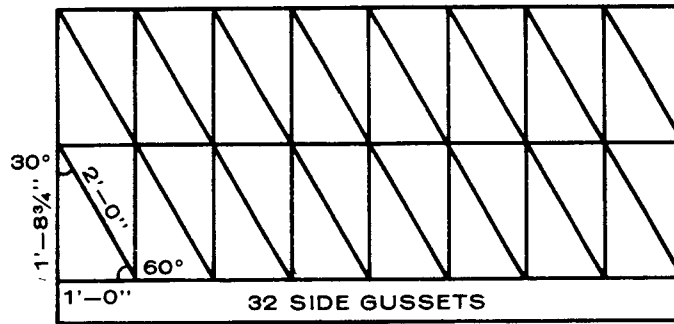

FIGURE 2.



STEP 8. TRUSSES

Lay out two rafters and two leg sections on a level area suitable for work. Now arrange the gussets using the inside width as specified in Table 2. Using a long piece of lumber (or 2 pieces nailed together) it is easy to get a square 90° angle from this base board to the leg. When this pattern is lined up, apply the side gussets and then the top gusset. The top gusset is set down 3 1/4 inches below the point where the catwalk will be nailed. A 2 X 4 spacer will be installed, during construction, between each truss and it will rest on the top gussets.

On this first pattern truss do not apply the 2 X 4 "A" brace (Step 7), since this truss can be used as the pattern and other trusses nailed together on top of it.

Brush or roll on a water-resistant wood glue in each of the 3 gusset areas. Nail on the gussets using No. 6 coated box nails. Space the nails about 3 inches apart.

On the pattern truss, mark clearly where the 2 X 4 "A" brace should fit, and on all succeeding trusses nail the brace in place.

STEP 9. PAINTING

Making trusses becomes routine and rapid after the first pattern is made. After assembling all the trusses, apply a good white primer paint followed by a coat of a good quality outside white paint. Outdoor latex base paints of good quality have been used satisfactorily. All of the structural lumber should be painted with two coats of paint before the house is actually constructed. Since the trusses will be set on 6 foot centers, most of the lengthwise framing pieces can be 18 footers which will make assembling easier and reduce waste. Paint the 4 X 4 posts and gussets at the base if used.

Painting also can proceed rapidly using soft rollers as well as a brush. Paint all of the edges with the trusses stacked in a pile and then paint each flat side. When the paint is dry, turn the trusses over onto a new pile and paint the other side. Two coats are needed; a primer and a finish coat. Two to three people working together can finish the painting in about 2-3 hours.

NOTE: ALL CONSTRUCTION NAILS SHOULD BE GALVANIZED IF POSSIBLE.

STEP 10. ASSEMBLING FRAME

At this point the posts are set and cut level, the trusses are made and painted, and all that remains is the simple job of assembling.

Using four people--two at each leg--lift the first truss in the air and set the base of the gusset upon the top of the 4 X 4 post and nail the 2 X 4 or 2 X 6 leg to the post using 20-penny nails. Unless you are building on a very windy day, all trusses can be nailed up simultaneously before attaching the lengthwise bracing. If in doubt, nail on the 2 X 6 X 18 foot pieces along the eaves.

All of the trusses (except the end two) should be exactly 6 feet apart, center to center. The two trusses on each end will be 5 feet 11 1/4 inches. This means that the 2 X 4 spacers that drop in between the trusses at the peak will be 5 feet 10 1/2 inches (this assumes that new 2 X 4 lumber is 1 1/2 inches thick).

All 14 of the spacers can be cut 5 foot 10 1/2 inches long and the two end spacers 5 foot 9 3/4 inches. Nail in the spacers with 16-penny nails. The spacers rest on the top gussets and the top of the spacer should be flush with the top of the truss. This provides a surface on which to nail the 2 X 6 catwalk.

The catwalk will be 96 feet long and can be 16 footers (use 6 - 2 inch X 6 inch X 16 foot lumber). Nail catwalk into vertical 2 X 4 spacers and into top edge of rafters.

The 2 X 6 lumber at the eaves should be 12 or 18 foot pieces (a multiple of 6 feet). These should be nailed on with 16-penny nails. Use one of the top spacers to get the same space at the peak and the eaves.

STEP 11. ADDITIONAL SUPPORT AND STABILITY.

Use four 2 X 4 X 18 foot pieces of lumber as diagonal braces (one in each corner, from the bottom of the "A" brace to the side gusset area (See picture, Page 14). Nail to each of the four rafters.

NOTE: ALL OF THIS LUMBER SHOULD HAVE BEEN PAINTED BEFORE ASSEMBLING.

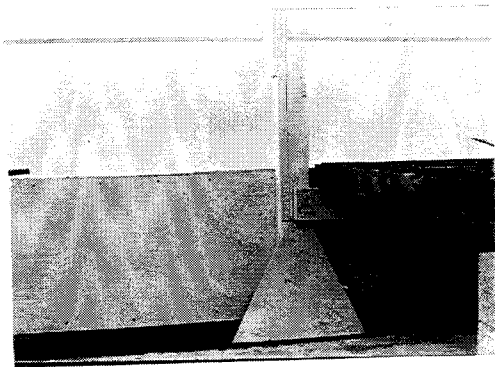
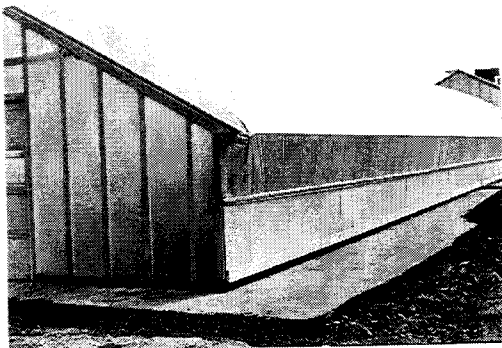
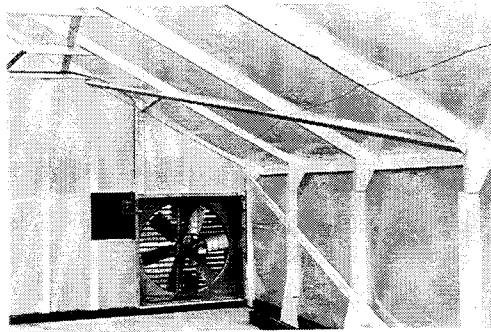
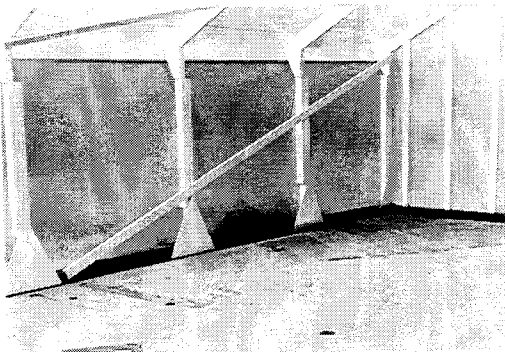
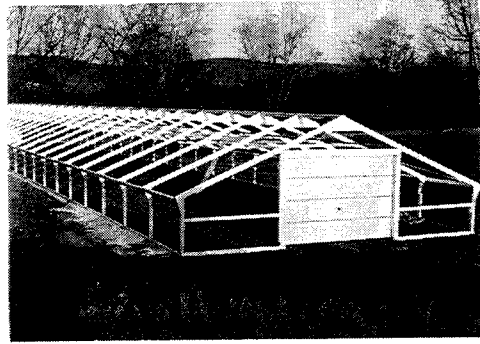
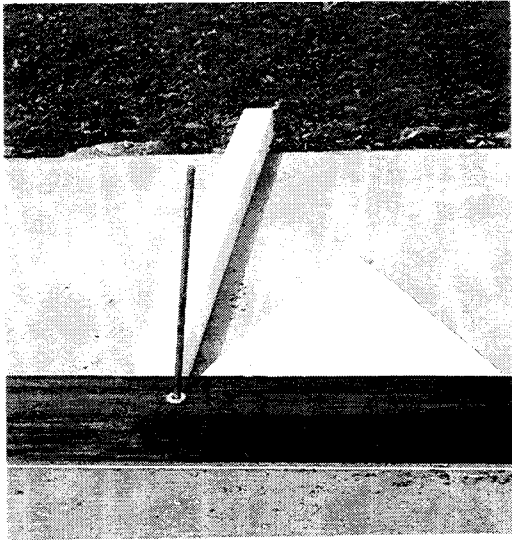

Using 16-penny nails, nail a 2 X 4 X 18 foot piece of lumber to each rafter just under, or on top of, the "A" brace--it is easier to nail if they are put underneath. On each end of the house place two additional 2 X 4 spacers between the first 2 rafters (8 per house). This prevents the ends from bowing in after inflation.

STEP 12. SIDE WALLS

For **House A** in Table 2, nail a 2 X 6 X 18 foot piece of lumber to the base of the 4 X 4 posts. The plastic will be attached to this lumber. If the side walls are not over 5 feet high there should be sufficient plastic from a 40 foot roll to make this attachment.

For **House B** in Table 2, one approach is to apply 3 feet of Homosote or plywood (1/2 inch thick) to the lower portion of the wall. Today, wider film is available and it can be used, and secured all the way down the side wall.

After the Homosote is attached, nail a 2 X 6 at the base and a 2 X 4 at the top of the Homosote. Through the inside, nail the Homosote to the lumber. The 40 foot plastic will be secured to the 2 X 4 at the top of the Homosote. It is sometimes desirable to omit the Homosote and use 2 layers of plastic on the base instead.

For **House C** in Table 2, the plastic will attach to the 2 X 6 at the eaves. Attach the plastic near the top of this piece of lumber and leave room to attach the separate plastic for the side walls. In this house, use two layers of plastic on the sides. If 12 or 14 foot lay-flat plastic film is used, it can be folded to have 2 layers that can be separated easily by air. A 2 X 6 piece of lumber along the bottom edge of the posts can be used as an attachment point.

STEP 13. APPLYING THE PLASTIC

The big day arrives when you get to this stage and it always gives one considerable concern the first time this job is tackled. The Cornell Plastic Greenhouse was designed to use 40 foot wide X 100 foot long polyethylene. This should be good ultraviolet resistant 6 mil greenhouse polyethylene, as previously stated. The various steps are listed below and if followed, the house should be covered in about 2 hours. It is best to have at least three or four people on hand to help. You will need four pieces of 2 X 4 painted lumber the same length as the rafters (2 X 2 will work if it is free of knots), and about 200 running feet of 1 X 3 to use along the sides.

NOTE: SIDE WALLS CAN BE COVERED BEFORE APPLYING THE TOP SHEETS, BUT IT IS SAFER TO ENCLOSE THE SIDES AND ENDS FIRST.

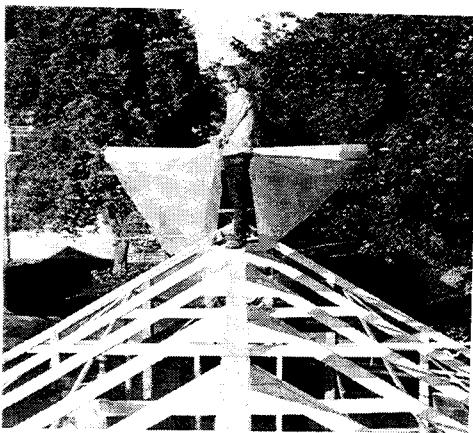
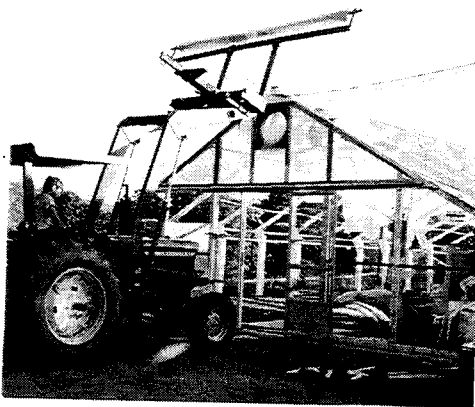
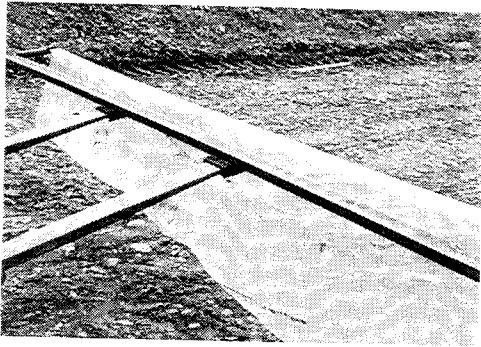

- A. A front-end loader on a tractor can easily be adapted with a pipe frame to serve as a plastic unroller or dispenser. The roll should be put on the roller and hoisted to the top of the house.

If a front-end loader is not available, the next best thing is to put a pipe through the core on the plastic roll and attach ropes to both ends of the pipe. Then with the ropes extending to the other end of the house, have a worker pull on the ropes. It will take a person walking the catwalk behind the roll to keep it in place. This is not the easiest method, but it can be done successfully in this manner.

If the loader unroller technique is used, a person can walk the catwalk and pull off the plastic while walking. Or, a long rope can be attached to the plastic and by pulling in the rope from the far end the plastic can be pulled the length of the house.

- B. Unfold the plastic and pull it down over the eaves, being careful to keep it even the entire length of the house.
- C. The next roll should then be applied before the first roll is attached, using the same technique as above.

- D. Attach the plastic to the rafters on one end. Cut the film at the peak and at the eaves to make rolling easier. Wrap a 2 X 4 piece of lumber into both layers of the film, evenly, and nail through the 2 X 4 and the plastic with double-headed 16- and 20-penny nails. Nail the plastic into the side of the rafter. By doing one rafter at a time you can be assured of a tight fit.
- E. To attach the plastic to the sides, use a 1 X 2 piece of lumber about 16 feet long, and roll the lumber in the plastic. It is best to cut the 2 layers of film at the end of each piece of lumber and roll it up a section at a time. (The section being the length of the lumber.) Nail through the film and the lumber into the 2 inch lumber beneath with 8-penny double head nails.
- F. To get air into the side walls, slip an 18 inch pieces of old garden hose between the layers (one at each corner). This will conduct air pressure from between the top layers into the side walls. At the corners, fit the plastic around the corners and staple in place.

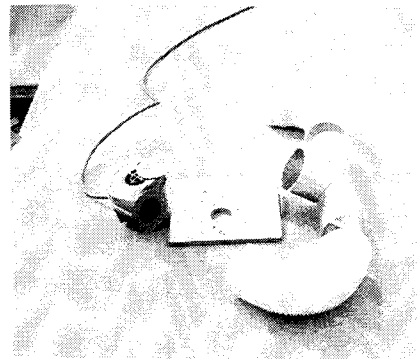
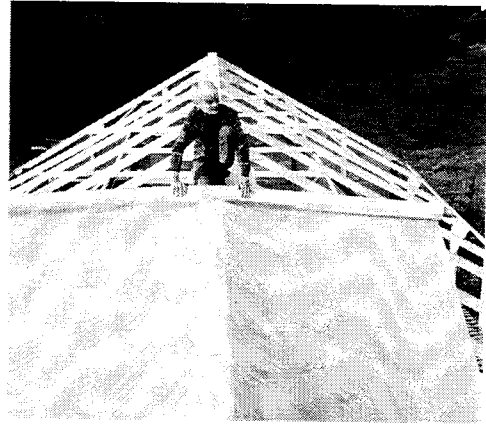

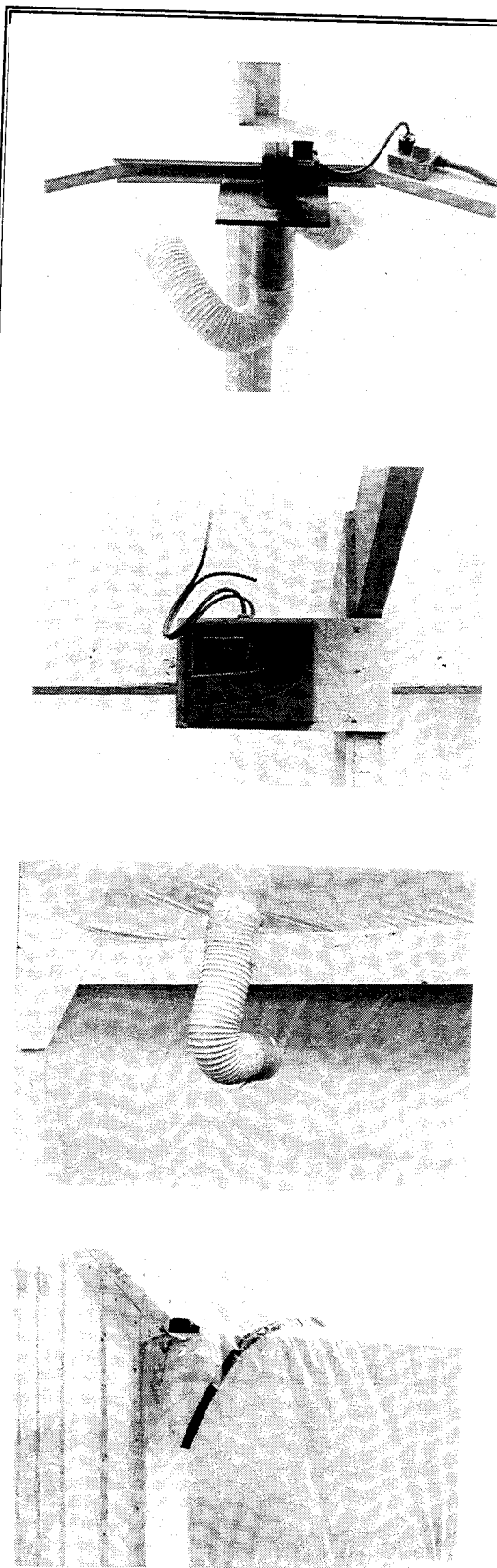

STEP 14. INSTALL BLOWER

A very small squirrel cage blower can be adapted quite easily to a 4 inch galvanized Tee with a piece of plywood. Attach a 4 inch piece of clothes drier vent tubing to the outlets on the Tee and mount the blower and Tee to the peak. The drier tubing can be taped into the inner plastic if a (+) cut is carefully made. Tape the ears of the plastic that will hang down from the (+) cut to the tubing. Do this on each side of the ridge. Wire the blower to an electrical source and turn on the blower. The roof should inflate in about one hour.

NOTE: The small blowers used at Cornell were Dayton Model 1C180. They have an automatic cutoff pressure of 0.6 inch water column pressure. The blower has a door on the intake side and by closing off this intake about 75%, it is easily possible to achieve the proper pressure which should be between 0.2 and 0.3 inch pressure. There have been no cases of the pressure being too high as to "blow-out" the film.

When in doubt regarding the air pressure, a simple manometer can be purchased and the pressure read directly, or a manometer can be made using a piece of clear plastic tubing about 24 inches long. Put some water in the tube (about 8 inches of water) and bend the tube to form a "U". Cut a small hole in the plastic and insert one end of the tube between the two layers of plastic and leave the opened end of the tube in the greenhouse. The difference between the two ends of the water column in the "U" should be roughly 1/4 inch.

STEP 15. SIDE WALL INFLATION

On houses such as **House C** in Table 2 (29 ft. 9 inches), where the side walls are covered with two layers of plastic, use a piece of 4 inch flexible tubing and insert one end into the bottom layer, using the (+) cut technique, and the other end into the inner layer of the side wall. Tape securely with plastic tape. The air will transfer from the roof to the side walls. This will produce good, rigid side walls with no flapping, as well as excellent resistance to heat loss.

NOTE: OUR DATA INDICATES THAT WHEN EMPLOYING A DOUBLE LAYER OF PLASTIC THERE IS A 40% SAVINGS IN UTILITIES, PLUS THE INNER LAYER STAYS DRIER.

COOLING

Open Sidewalls: For a large portion of the year one of the biggest problems in managing a plastic greenhouse is cooling. Even with adequate fans, heat buildup becomes a severe problem and most times it can be 10 - 20° hotter in the greenhouse. Experiences in operating a greenhouse with the sides completely open from late May until early October have been very good. Open sidewalls can save electrical energy, as well as stimulate better growth of plants, which makes it a very desirable practice.

If you decide to use open sidewalls, the sides should be enclosed with one-inch mesh chicken wire to keep out animals. However, if insects are a problem, a very fine mesh may be substituted.

Open sidewalls lower the temperature in the greenhouse during hot weather and it is an excellent method which helps to control the quality of bedding plants late in the season; as well as for any crop grown during the summer and early fall, and the roof keeps the rain off the plants. The air supported two layer roof is fully adequate to tolerate heavy winds.

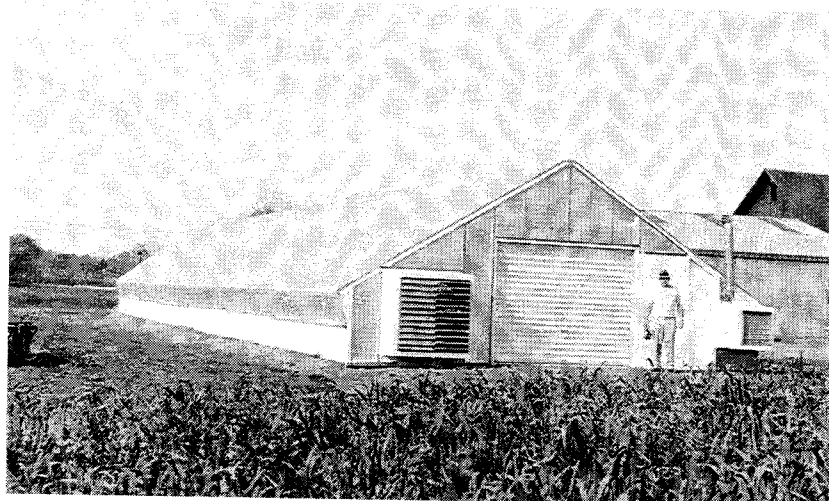

HEATING

A plastic greenhouse can be heated with steam, hot water, or hot air, and can utilize any of the conventional fuels. Heating is usually considered to be the main expense involved in a greenhouse operation; however, the biggest cost factor is the labor for maintenance. Your greenhouse heating system should be one that is fully automatic and as free from maintenance labor as possible.

If a very large heating operation is to be built, the ideal arrangement would be to utilize a central heating plant where a boiler could be located and the hot water or steam lines piped out to the various houses. The steam from this boiler could then be used to sterilize (pasteurize) soils. Such an installation may appear more costly at the outset, but it will be more economical in the long run.

Generally speaking, single unit heaters in each house are most frequently fired with natural or L.P. gas, and to a lesser extent, fuel oil. Such systems work best if the circulation fans on the heaters are operated continuously and the thermostats wired to control the burner. Such a method gives a more uniform temperature distribution and minimizes the vertical stratification of the heat.

HEATERS (ONE OR MORE?): If the house is to be heated with a unit heater, it is certainly more worthwhile to use two smaller units rather than one large capacity unit. The additional cost is small if one considers the added insurance value over a ten year period. With two heaters instead of one, you do not have "all of your eggs in one basket". If one heater fails, the other one could act as a backup and prevent a total crop loss. For this reason, a temperature alarm system should be an integral part of your system, and a small stand-by electrical generator is a must.

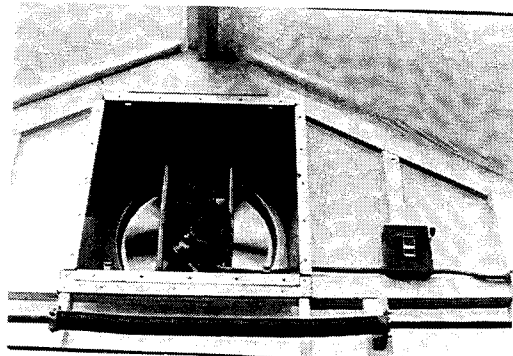
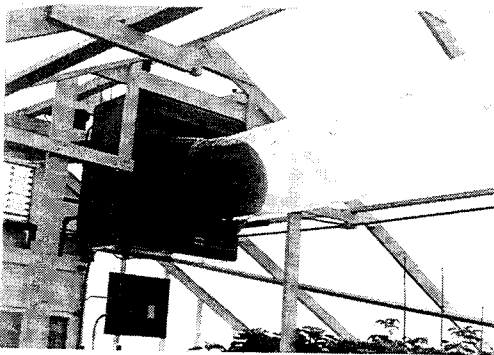

SIZING HEATERS: To determine the size of the heater(s) needed, determine the total exposed surface area (A) in square feet (i.e., do not include floor area). Next, determine the coldest outside temperature (t_o) expected during the period of operation and then decide upon the temperature desired inside the house (t_i). As a rule, use the desired night temperature which is generally 10° cooler than the day temperature.

The heat transfer coefficient (u) for a double layer house is 0.70 and for a single layer house it is best to use 1.2, or better yet, 1.3. **NOTE: Single layer houses are not recommended!** The heat (H) in BTU per hour can readily be determined by the equation in Example 1:

EXAMPLE 1: 26 X 96 FOOT PLASTIC GREENHOUSE WITH 5 FOOT SIDE WALLS:

$$\begin{array}{rcl}
 \text{Top - 16 X 96} & = & 1536 \\
 \text{(Other side)} & = & 1536 \\
 \\
 \text{Sides 16 X 5} & = & 480 \\
 & & 480 \\
 \\
 \text{Ends} & = & 234 \\
 & = & \underline{234} \\
 & & 4500 \text{ Sq. ft.} = A \text{ (surface area)}
 \end{array}$$

$$\begin{array}{l}
 H = u(A) (t_i - t_o) \\
 H = 0.70(4500)(60) \\
 = 0.70 \times 4500 \times 60 \\
 H = 189,000 \text{ BTU's for a double layer house} \\
 H = 351,000 \text{ BTU's for a single layer house}
 \end{array}$$

(t _i -t _o)	BTU	
	Double	Single
30	95,000	176,000
40	126,000	234,000
50	157,500	292,000
60	189,000	351,000
70	220,500	409,500

NOTE: Using Example 1 on Page 21 for a 26 foot plastic greenhouse, you can decide what furnace or heater size is needed. If the house will only be used for bedding plants, you may find that a temperature differential of 30 or 40° might be adequate. However, it would be wise to utilize two unit heaters instead of one, and calculate an extra 25% heating capacity should you decide later to use the house during colder weather, or grow crops requiring warmer temperatures. Unit heaters can be obtained with blower units on the back instead of propeller units. Since poly tubes are generally used to conduct heat, the blower-type unit is suggested to handle the pressure requirements.

HEAT PLACEMENT: Deciding where to place the heat source is often a controversial subject. In houses 100 feet long, fan-operated unit heaters have successfully been located about 15 - 20 feet from one end of the house, in a corner. Ideally, in houses this long, two smaller heaters are better since the theoretical "throw" of air from the fan is about 50 feet. Two heaters (one at each end and at opposite corners) would give a large degree of insurance of even heat distribution. Connecting perforated polyethylene tubes to the heaters will aid in distributing the heat down each side of the house, as the sides are usually the coldest areas. Many growers prefer placing the heaters in the peak and attaching polyethylene tubing to the outlet. If two heaters are used, they can be placed in the peak at opposite ends. Separate polyethylene tubes can be attached to deliver air half way down the house. The tubes should have air discharge holes, a minimum of 3 inches in diameter, at the 3 and 9 o'clock position or even slightly higher. Again, blower units are suggested where tubes are used rather than propeller types.

One modification is to use two heaters and an air mixing box which uses a separate belt-driven fan in order to carry heat down the tube, circulate the air within the greenhouse, and circulate fresh air when the intake louver is open. These fan/air mixing box units are commercially available.

AIR SUPPLY FOR HEATERS: All unit heaters require plenty of air to provide the oxygen that is extremely essential for complete combustion of the fuel. Plastic houses can be made airtight. Therefore, an air intake duct to the heater should be provided. A rule of thumb: one square inch of free air intake for each 2000 BTU of furnace size. Therefore, a 100,000 BTU heater should have an intake duct 50 square inches in size. A simple technique would be to install a 7 inch diameter stove pipe to the outside and extend it to the area under the heater. Be sure to place a screen over the end to keep out small animals.

Combustion of fuel is taken as a rather simple process, but an understanding of the process is essential to good greenhouse management. For example, when propane gas (C₃H₈), is combined with oxygen (O₂) in the burning cycle, it produces heat (BTU's). However, the by-products of combustion are carbon dioxide (CO₂) and water (H₂O). The chemical reaction is:

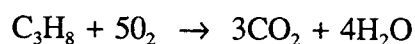

Therefore, by simple calculation it requires 3.64 pounds of oxygen to burn one pound of propane. Since air is only 20% oxygen, it takes 15.8 pounds of air to combust one pound of propane. (Air for free, so there is no need to starve the heaters of air!) Also, 1.6 pounds of water are given off each time a pound of propane is burned. Therefore, the heaters should be vented to the outside, otherwise a wet, drippy condition will develop inside the house. Approximately 3.0 pounds of CO₂ from each pound of propane burned is produced. However, the heaters run mostly at night and carbon dioxide is not needed by plants at night. The same reasoning exists regardless of what fuels are used.

VENTILATION

To produce quality plants in a greenhouse, it is very important to prevent high temperatures. To reduce high temperatures, ventilation is necessary. However, proper ventilation is often neglected. The simplest and most efficient way to ventilate plastic greenhouses is with exhaust fans. To find the size of the fan needed, determine the number of cubic feet of air in the house by calculating the square feet of surface area in one end wall and multiply this figure by the length of the house. For example, the 26 X 96 foot house with 6 foot side walls needs fans capable of moving about 23,000 cubic feet of air per minute (cfm).

All fans are rated in cfm, and the fan used for ventilation should be capable of at least one air change per minute. The cfm rating of the fan(s), therefore, should either correspond to, or be larger than, the cubic feet of air space. A two-speed motor is advantageous and, in larger houses, two or more fans with two-speed motors will increase the flexibility and the success of ventilating.

Ventilating fans should operate as exhaust fans, blowing the air outside. Therefore, space for air to enter is important. During periods of hot, sunny weather, this is a simple problem if enough space for air intake is provided. For maximum efficiency the area should be at least four or five times larger than the fan opening. In cold weather, however, a uniform distribution of incoming air can be a more difficult problem. Large polyethylene tubes, 18 - 24 inches in diameter, hung along the peak of the roof, provides a practical solution. The fan is mounted as usual in one end, or in the roof of the house. Holes 3 inches in diameter are cut in the plastic tube every 3 feet on each side. One end of the tube an opening is connected to the outside of the house; the other end, at the opposite end of the house, is tied shut. When the fan are turned on, a vacuum in the house is created, and air rushes into the tube and inflates it. The incoming air flowing through the holes in the tube is then distributed throughout the house, and cold blasts in any one area are eliminated. In long houses, or for a greater volume of air, both ends can be connected to tubes, or two tubes can be used. Another approach to the intake problem is to use motorized louvers on the intake ends.

A multipurpose tube ventilation system provides for all air handling and ventilating needs in a greenhouse during cool and winter seasons. Basically, this system employs a special fan component at the inlet of the plastic tube mentioned on the previous page. The fan operates continually, circulating air within the greenhouse, and also employs inlet shutters which open and allows outside air to enter when cooling is required. This type of system gives excellent temperature distribution, reduces relative humidity, and circulates carbon dioxide uniformly.

On occasion there may be a period of time when there is no call for heat and therefore, no ventilation is demanded by the thermostat. This "twilight zone," as we call it, can be a difficult period. Under these conditions the humidity rises, and the inner plastic and foliage gets wet, and disease may become a real problem. Constant air circulation from the big tube in the ceiling is recommended, but if the air is saturated and moisture is condensing on the cold surfaces, more control is needed. To reduce the quantity of moisture in the greenhouse when heaters are not operative, you can remove some moist inside air (ventilation) and bring in some cooler (drier) air from the outside. Although this may cause the heat to run more frequently, it is an effective way to combat the problem. The added utility cost will scarcely be noticed, but the freedom from moisture and disease will be great.

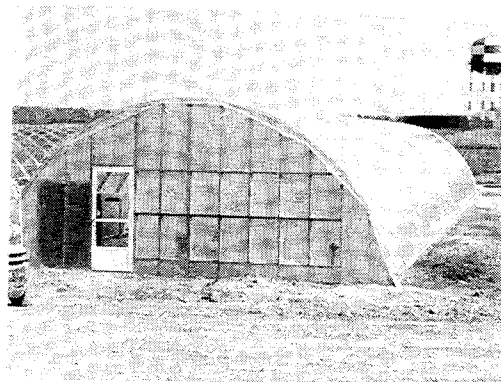
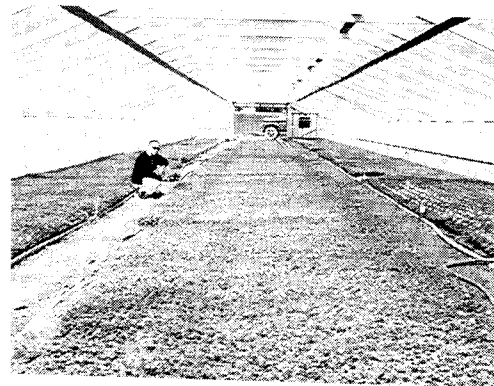
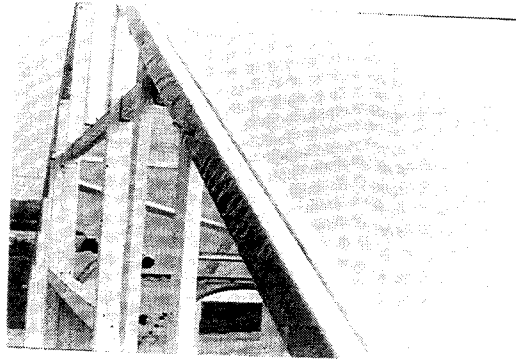
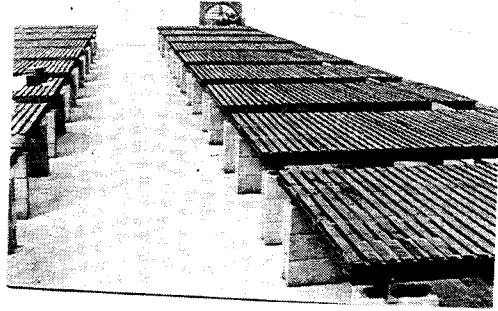

Quonset Style

The easiest way to achieve moisture reduction in the house, on a foolproof basis, is to install a small fan (18 - 24 inches) that has the capability in cfm of an air change every 5 minutes. This fan should be installed to exhaust out at either end. Install a time clock (30 - 60 minute timer) into the line voltage so that it is set to go off for a short period of time every 15 or 30 minutes if this problem exists in your greenhouse. A 2 minute "on" cycle every 15 minutes, for a total of 8 minutes per hour, both night and day should help to eliminate the moisture. A small intake louver near the peak at the opposite end can be used to bring outside air in, or if you have motorized louvers plus a tube, it is possible to have these open at the same time. This is the same good management practice found in a glass house where the top vents are frequently left open a crack, which essentially does the same thing since the warm moist air rises and goes out the vent.

FIGURE 3.

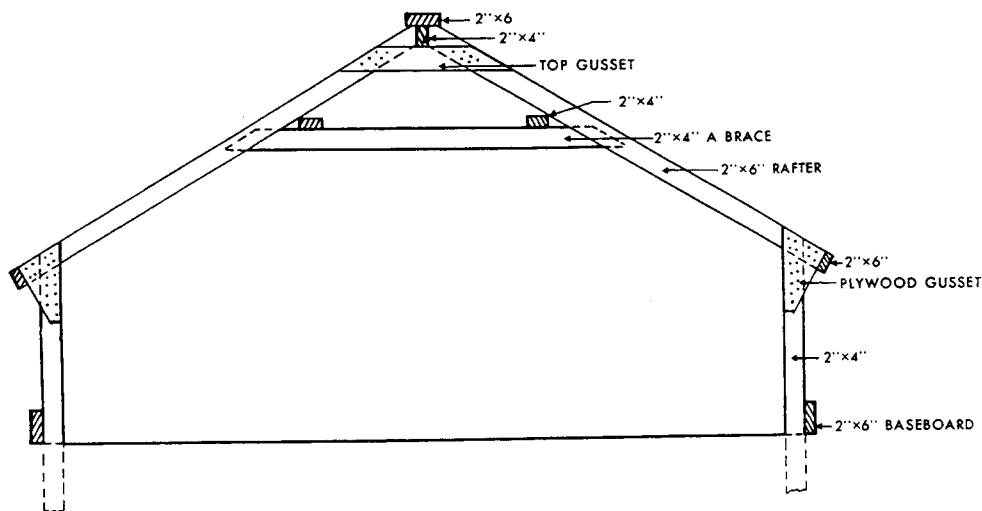

**BILL OF MATERIALS FOR A CORNELL "TWENTY-SIX"
PLASTIC GREENHOUSE (26 x 29 FT.)**

34	2x6x16' rafters	@	7.47	\$ 253.98
17	2x4x10' Legs	@	3.29	55.93
17	2x4x14' "A" Brace	@	4.54	77.18
6	2x6x16' Catwalk	@	7.47	44.82
6	2x4x18' Catwalk spacer	@	6.10	36.60
11	2x6x18' Eaves	@	8.54	93.44
11	2x6x18' Baseboard	@	8.54	93.44
11	2x4x18' Top Brace			
	for Homosote	@	6.10	67.10
34	4x4x8' Posts -			
	if set in ground	@	8.00	272.00
11	2x4x18' Lengthwise Braces	@	6.10	67.10
4	2x4x20' Diagonal Brace	@	7.20	28.80
2	Sheets 4x8x1/2 AC Exterior	@	18.00	36.00
Plywood - 68	Side gussets 32 per sheet			
2	Sheets 4x8x1/2 AC Exterior	@	18.00	36.00
Plywood - 34	Top gussets			
2	Sheets 6 mil 40x100 ft.	@	196.00	392.00
150 ft. (approx.)	2x4 end framing	@	.33	49.50
64 ft. (approx.)	4x4 door framing	@	1.00	64.00
400 sq. ft. rigid plastic for ends		@	1.00	400.00
	(est.)			
2	Heaters (175,000 BTU)	@	1450.00	2900.00
	Accessories			200.00
1	Fan(48-52 in.) 3/4-1 h.p.			
	motor	@	736.00	736.00
1	Fan (24-30 in.) 1/3-1/2 h.p.	@	253.00	<u>253.00</u>
	motor			
		TOTAL		*6120.89
2	Overhead doors - This is optional but highly recommended.			1000.00

Cost are based on 1991-92 prices - you may need to compensate for inflation and annual price increases.

SUMMARY

In this manual the details of building one type of polyethylene covered greenhouse has been discussed. The painted wood frame houses are very practical and attractive looking. Moreover, they are constructed of standard dimension lumber and all of the components can be purchased at conventional lumber yards. Much of the information in the manual can be applied to other types or designs, as well.

At the time of writing this manual, much interest was expressed by growers in the pipe frame or quonset style greenhouse (see photo, Page 24). These are most generally purchased from a commercial manufacturer and if two layers of film with an air cushion between are employed, these houses are very practical. The decision of which shape and whether wood, steel, or aluminum is to be used, is a personal decision.

There is also a great deal of interest in covering extensive land areas with ridge and furrow type houses. If this is done in areas of heavy snowfall, the structure must be designed with this in mind and plenty of heat should be available to aid in melting the large amounts of snow that accumulates in the furrows. From a labor management standpoint, these types have many advantages. Naturally they are more economical to heat because you have less side walls.

Regardless of the design you use, plan for the utmost in labor efficiency. Managing a greenhouse is a materials handling business and anything that can be done to improve the flow of materials "in and out" will save labor costs. A properly heated and ventilated plastic house can be used to grow any kind of plant, and growth will be just as good as in glass houses. Plastic houses have enabled many young growers to get started with limited capital. They are excellent growing structures and have served our industry well.